



VX4353
Relay Switching Module
Operating Manual

Tektronix

WARRANTY

This Tektronix, Inc. product is warranted against defects in materials and workmanship, and is warranted to meet the performance specifications as listed in the current catalog and/or data sheet for this product. This warranty applies for three (3) years following the date of shipment. Tektronix will, at its option, repair or replace, at no cost to the customer, this product should it prove to be defective during the warranty period, provided the defect or failure is not due to misuse or abuse of the product. The customer is responsible for shipment of the defective product to the Tektronix repair facility. NO OTHER WARRANTY IS EXPRESSED OR IMPLIED, INCLUDING WARRANTY FOR FITNESS OF PURPOSE. TEKTRONIX INC. SHALL, IN NO CASE, BE LIABLE FOR CONSEQUENTIAL DAMAGES.

TRADEMARK NOTIFICATION

GW BASIC is a registered trademark of the Microsoft Corporation.

IBM PC is a registered trademark of the IBM Corporation.

VXIbus is a trademark of the VXI Consortium.

All other brand and product names are trademarks or registered trademarks of their respective companies.

© Copyright 1992 by
Tektronix, Inc.
Beaverton, OR 97077
All rights reserved.

Printed in U.S.A.

VX4353 MODULE QUICK REFERENCE GUIDE

Numbers in parentheses refer to the page(s) in the Operating Manual.

SETUP

Be sure all switches are correctly set. (p. 1 - 3)
Follow Installation guidelines. (p. 2 - 1)

The default condition of the VX4353 Module after the completion of power-up self test is that all relays are open.

LEDs

When lit, the LEDs indicate the following:

Power	power supplies functioning
Failed	module failure
Message	module is processing a VMEbus cycle
CH00 - CH3 1	the associated relay is closed

SYSTEM COMMANDS

All VXibus commands are accepted (e.g. DTACK * will be returned). VXI V1.3 commands have effect on this module. See the Specifications section for details.

COMMAND SYNTAX

Command protocol and syntax for the VX4353 Module is as follows: (3 - 2)

- o Commands may be used in either the long or short form.
- o Any character may be sent in either upper or lower case form.
- o Commands are executed on receipt.
- o The message terminator may be a line feed and/or EOM bit.
- o Query commands (Q, T, and IDN) require a terminator. All other commands may be strung together with only the final command in the string requiring a terminator.

Commands may be used in either long or short form.

MODULE COMMANDS

<u>Short/Long Form</u>	<u>Effect</u>
Cz CLOSEz	closes relay z. (3 - 3)
Dz DELAYz	assigns time delay. (3 - 4)
IDN?	returns identification message. (3 - 5)
Oz OPENz	opens relay z. (3 - 6)
Qz QUERYz	queries relay z for status. (3 - 7)
R RESET	resets (opens) all relays. (3 - 8)
S SET	sets (closes) all relays. (3 - 9)
T TIME?	queries time delay. (3 - 10)

PROGRAMMING

The programming examples in the manual are written in Microsoft GW BASIC. For programming examples, see page 4 - 1.

CALL ENTER (R\$, LENGTH%, ADDRESS%, STATUS%)
Inputs data into the string R\$ from the IEEE-488 instrument whose decimal primary address is contained in the variable ADDRESS%. LENGTH% = the number of bytes read from the instrument. STATUS% = '0' if the transfer was successful; '8' if an operating system timeout occurred in the PC. To use the CALL ENTER statement, the string R\$ must be set to a string of spaces whose length is greater than or equal to the maximum number of bytes expected from the 73A-332.

CALL SEND (ADDRESS%, WRT\$, STATUS%)
Outputs the contents of the string variable WRT\$ to the IEEE-488 instrument whose decimal primary address is in the variable ADDRESS%. The variable STATUS% = '0' if the transfer was successful and an '8' if an operating timeout occurred in the PC.

END Terminates the program.

FOR/NEXT

Repeats the instructions between the FOR and NEXT statements for a defined number of iterations.

GOSUB n Runs the subroutine beginning with line n. The end of the subroutine is delineated with a RETURN statement. When the subroutine reaches the RETURN statement, execution will resume on the line following the GOSUB command.

GOTO n Program branches to line n.

IF/THEN Sets up a conditional IF/THEN statement. Used with other commands, so that IF the stated condition is met, THEN the command following is effective.

REM All characters following the REM command are not executed.

RETURN Ends a subroutine and returns operation to the line after the last executed GOSUB command.

<CR> Carriage return character, decimal 13.

<LF> Line feed character, decimal 10.

Table of Contents

Section 1

General Information and Specifications

Introduction	1 - 1
Controls And Indicators	1 - 3
Switches	1 - 3
LEDs	1 - 4
Fuses	1 - 4
BITE (Built-In Test Equipment)	1 - 5
Specifications	1 - 6

Section 2

Preparation For Use

Installation Requirements And Cautions	2 - 1
Installation Procedure	2 - 2
Installation Checklist	2 - 5

Section 3

Operation

Overview	3 - 1
Power-up	3 - 1
System Commands	3 - 1
Module Commands	3 - 2
Command Syntax	3 - 2
Summary	3 - 2
Command Descriptions	3 - 3
SYSFAIL, Self Test, and Initialization	3 - 11

Section 4

Programming Examples

Definition of BASIC Commands	4 - 1
Programming Examples In BASIC	4 - 2

Appendix A - VXIbus Operation	A - 1
--	-------

Appendix B - Input/Output Connections	A - 3
--	-------

Appendix C - VXI Glossary	A - 5
--	-------

Operators Safety Summary

The general safety information in this summary is for both operating and servicing personnel. Additional specific warnings and cautions are found throughout the manual where they apply, and may not appear in this summary.

TERMS

In This Manual

WARNING statements identify conditions or practices that could result in personal injury or loss of life.

CAUTION statements identify conditions or practices that could result in damage to the module or other property.

Marked on the Module

DANGER indicates a personal injury hazard immediately accessible as one reads the marking.

CAUTION indicates a personal injury hazard not immediately accessible as one reads the marking, or a hazard to property, including the module itself.

SYMBOLS

In This Manual



This symbol indicates where applicable cautionary or other information is to be found.



This symbol indicates where special explanatory information is included in the manual. There is no caution or danger associated with the information.

Marked on the Module



DANGER — High Voltage.



Protective ground (earth) terminal.



ATTENTION — Refer to the manual.



Refer to manual before using.

Power Source

This module is intended to operate in a mainframe whose power source does not apply more than 250V rms between the supply conductors or between either supply conductor and ground. A protective ground connection through the grounding conductor in the power cord(s) is essential for safe operation.

Grounding the Module

This module is grounded through the grounding conductor of the mainframe power cord(s). To avoid electrical shock, plug the mainframe power cord(s) into a properly wired receptacle before connecting to the module connectors. A protective ground connection through the mainframe is essential for safe operation.

Danger Arising from Loss of Ground

Upon loss of the protective-ground connection, all accessible conductive parts can render an electric shock.

Use the Proper Fuse

To avoid fire hazard, use only fuses specified in the module parts list. A replacement fuse must meet the type, voltage rating, and current rating specifications required for the fuse that it replaces.

Do Not Operate in Explosive Atmosphere

To avoid explosion, do not operate the module in an explosive atmosphere.

Do Not Remove Covers or Panels

To avoid personal injury, the module covers should be removed only by qualified service personnel. Do not operate the module without covers and panels properly installed.

VX4353

Relay Switching Module

Section 1

General Information and Specifications

Introduction

The VX4353 Relay Switching Module is a printed circuit board assembly for use in a mainframe conforming to the VXIbus Specification, such as the VX1400 "C" size mainframe used in the Tektronix/CDS IAC System. The module provides 32 independently controlled single-pole, single-throw relays. Individual relays or all relays can be opened or closed under program control.

The amount of delay between successive operations and the relay closure dwell time can be controlled by software. Delay times from 0 to 65535 milliseconds can be selected. The module is programmed by transmitting ASCII characters from the system controller through the VXI system to the module.

The module's commands also provide access to system information. The position of any individual relay (open or closed) may be read back by the system controller and is also displayed by LEDs on the module's front panel. Other commands return the programmed time delay and identification information about the module.

Note that certain terms used in this manual have very specific meanings in the context of a VXIbus System. A list of these terms is presented in the VXIbus Glossary (Appendix C).

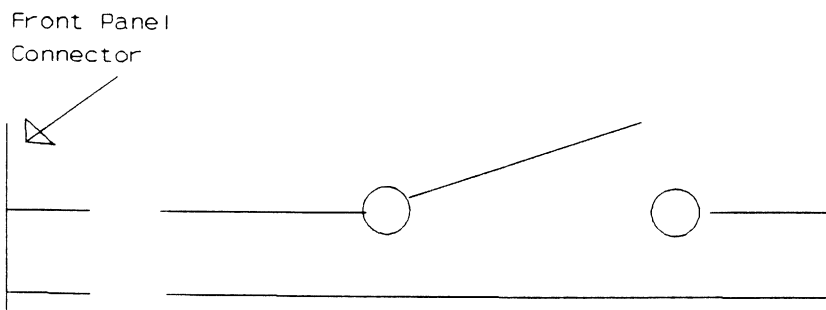

Figure 1: Typical SPST Relay

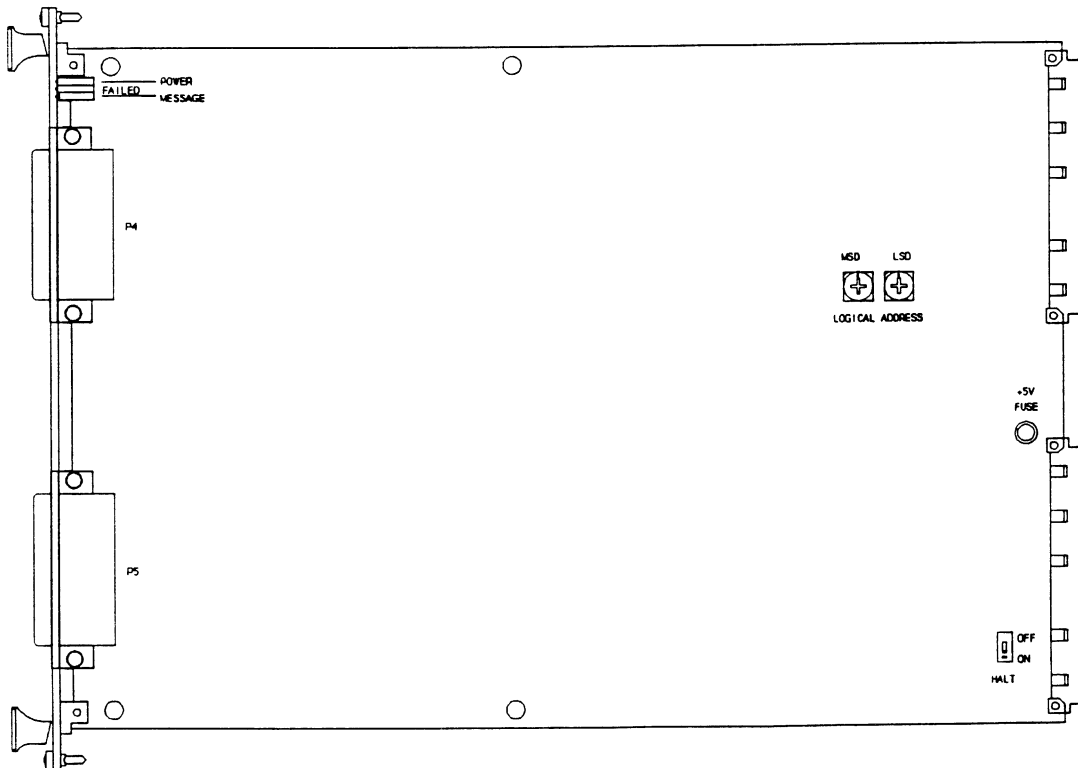

Figure 2: VX4353 Controls and Indicators

Controls And Indicators

The following controls and indicators are provided to select and display the functions of the VX4353 Module's operating environment. See Figures 1 and 2 for their physical locations.

Switches

Logical Address Switches

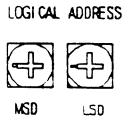

Each function module in a VXibus System must be assigned a unique logical address, from 1 to 255 decimal. The base VMEbus address of the VX4353 is set to a value between 1 and FFh (255d) by two hexadecimal rotary switches. Align the desired switch position to the arrow on the module shield.

The actual physical address of the VX4353 Module is on a 64 byte boundary. If the switch representing the most significant digit (MSD) of the logical address is set to position X and the switch representing the least significant digit (LSD) of the logical address is set to position Y, then the base physical address of the VX4353 will be $[(64d * XYh) + 49152d]$. For example:

	M	L	
L. A.	S	S	Base Physical Addr. (d)
Ah	0	A	$(64 * 10) + 49152 = 49792d$
15h	1	5	$(64 * 21) + 49152 = 50496d$

where: L.A. = Logical Address
MSD = Most Significant Digit
LSD = Least Significant Digit

IEEE-488 Address

Using the VX4353 Module in an IEEE-488 environment requires knowing the module's IEEE-488 address in order to program it. Different manufacturers of IEEE-488 interface devices may have different algorithms for equating a logical address with an IEEE-488 address.

If the VX4353 is being used with a Tek/CDS IEEE-488 interface module, consult the operating manual of the Tek/CDS Resource Manager/IEEE-488 Interface Module being used.

If the VX4353 is not being used with a Tek/CDS Resource Manager/IEEE-488 Interface Module, consult the operating manual of the IEEE-488 interface device being used for recommendations on setting the logical address.

Halt Switch



This two-position slide switch selects the response of the VX4353 Module when the Reset bit in the module's VXibus Control register is set. Control of the Reset bit depends on the capabilities of the VX4353's commander.

If the Halt switch is in the ON position, then the VX4353 Module is reset to its power-up state and all programmed module parameters are reset to their default values.

If the Halt switch is in the OFF position, the module will ignore the Reset bit and no action will take place.

Note that module is not in strict compliance with the VXIbus Specification when the Halt switch is OFF.

LEDs

The following LEDs are visible at the top of the VX4353 Module's front panel to indicate the status of the module's operation:

Power LED

This green LED is normally lit and is extinguished if the +5V power supply fails or the +5V fuse opens.

Failed LED

This normally off red LED is lit whenever SYSFAIL* is asserted, indicating a module failure.

If the module's +5V fuse opens, the Failed LED will be lit and SYSFAIL* asserted. A module power failure is also indicated when the module's Power LED is extinguished.

Message LED

This green LED is normally off. When lit it indicates that the module is processing a VMEbus cycle. The LED is controlled by circuitry that appears to stretch the length of the VMEbus cycle. For example, a five microsecond cycle will light the LED for approximately 0.2 seconds. The LED will remain lit if the module is being constantly addressed.

Channel LEDs

The column of 32 green LEDs represent relays 00 through 31, reading from top to bottom. A lit LED indicates that the associated relay is closed.

Fuses

The VX4353 Module has one +5V, 5 amp fuse. The fuse protects the module in case of an accidental shorting of the power bus or any other situation where excessive current might be drawn.

If the +5V fuse opens, the VXIbus Resource Manager will be unable to assert SYSFAIL INHIBIT on this module to disable SYSFAIL*.

If the +5V fuse opens, remove the fault before replacing the fuse. Replacement fuse information is given in the Specifications section of this manual.

BITE (Built-In Test Equipment)

Any individual channel position can be interrogated under program control to determine if the relay is open or closed. The controller signal for each relay is connected both to the channel LED and to a separate input buffer. The module can also return information on the programmed time delay and module identification information.

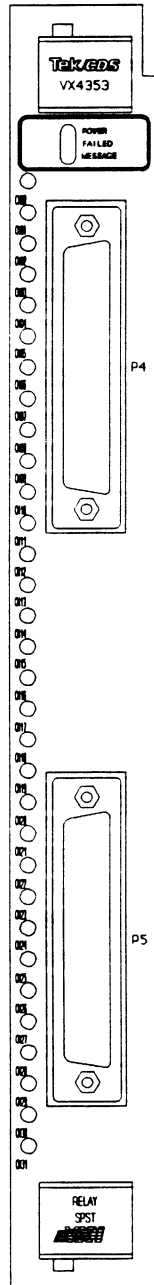

Figure 3: VX4353 Front Panel Display

Specifications

Configuration: 32 single-pole single-throw (SPST) relays.

Relay: Aromat Corporation model S2EB-5V (per CDS specification).

Contact Ratings: Maximum switching power:
1000 VA ac, 90 W dc.
Maximum switching voltage:
250 V ac, 48 V dc.
Maximum switching current:
5 A (<40 operations per minute)

Maximum Power Dissipation Per Connector: 1 Watt. To determine the current capacity for specific applications, assume 20 milliohms resistance per pin.

Maximum Operating Speeds: 100 operations per second.

Programmable Relay Delay: 0 to 65,535 msec.

Recommended Maximum Operating Conditions and Operational Life:

<u>Rate*</u>	<u>Volts</u>	<u>Amps</u>	<u>Op. Life*</u>
40 OPM	30 V dc	3.0 A	2 x 10 ⁶
40 OPM	250 V ac	4.0 A	10 ⁵
40 OPM	130 V ac	5.0 A	1 x 10 ⁴
40 OPM	20 V dc	5.0 A	2 x 10 ⁵
20 OPS	30 V dc	2.0 A	10 ⁶
20 OPS	250 V ac	2.0 A	10 ⁶
100 OPS	1 V dc	1.0 mA	10 ⁶

NOTE: OPS - operations per second
OPM - operations per minute
Op Life - operational life

An operation is defined as a close or an open. A close/open cycle is two operations.

* Values are for a 5% failure probability.

Duty Cycle: Continuous.

Dwell: Recommended dwell time at maximum switching rate is 4 msec minimum.

Signal Path Specifications: Single-line thermal offset:
Less than 10 microvolts.

Signal path resistance:

Initial: Less than 300 milliohms.

After full load-life: Less than 400 milliohms.

Insulation resistance:

Greater than 10 Gigohms.

**Isolation - Wiper to
Open Contact:**

1 kHz	Less than -90 dB.
10 kHz	Less than -80 dB.
100 kHz	Less than -60 dB.
1 MHz	Less than -42 dB.

Measurement was made on the normal open contact with a 600 ohm termination. The signal was applied to the wiper of the relay.

**Crosstalk
Between Channels:**

1 kHz	Less than -100 dB.
10 kHz	Less than -80 dB.
100 kHz	Less than -65 dB.
1 MHz	Less than -47 dB.

Measurement was made on a closed relay with a 600 ohm termination and signal applied into an adjacent channel, open or closed relay, with and without 600 ohm termination.

Power Up:

When power is turned on, all relays are open.

Power Down:

When power is turned off, all relays are open.

VXIbus Compatibility:

Fully compatible with the VXIbus Specification for V1.3 message-based instruments with the Halt switch in the ON position.

Device Type:

VXI message based instrument, V1.3.

VXI Protocol:

Word serial.

VXI Card Size:

C size, one slot wide.

**Module-Specific
Commands:**

All module-specific commands and data are sent via the VXIbus Byte-Available command. All module-specific commands are made up of ASCII characters. Module-specific data may be in either ASCII or binary format.

VMEbus Interface:

Data transfer bus (DTB) slave - A16, D16 only.

VXIbus Data Rate:

300K bytes/sec maximum.

**VXIbus
Commands Supported:**

All VXIbus commands are accepted (e.g. DTACK* will be returned). VXI V1.3 commands have effect on this module.

All Primary, MBD, VXIbus Instrument-required commands are supported:

- Abort Normal Operation
- Begin Normal Operation
- Byte Available
- Byte Request
- Clear
- End Normal Operation
- Read Protocol
- Read Protocol Error

The following additional commands are supported:

- Read STB
- Read Interrupters
- Asynchronous Mode Control
- Control Event
- Control Response
- Set Lock
- Clear Lock
- Trigger

All other commands will generate Word Serial Protocol 'Unsupported Command' errors.

VXIbus Registers:

- ID
- Device Type
- Status
- Control
- Protocol
- Response
- Data Low

See Appendix A for definition of register contents.

Power Requirements:

All required dc power is provided by the power supply in the VXIbus mainframe.

Voltage:

5 volt supply: 4.75 V dc to 5.25 V dc.

Current (Peak Module, I_{PM}):

5 volt supply: 2.2 amps PTP.

Cooling:

Provided by fans in the VX1400 Mainframe. The module will have a temperature rise of $< 10^{\circ}\text{C}$ with 0.9 liters/sec per slot of air and a pressure drop of 0.16 mm of H_2O .

For 10°C rise, 0.9 liters/sec air at 0.01 mm of H_2O .

Fuses:

Replacement fuse: Littlefuse P/N 273005; CDS P/N 42202-73050.

Section 1

Temperature:	0°C to +50°C, operating. -40°C to +85°C, storage.
Humidity:	Less than 95% R.H. non-condensing, 0°C to +30°C. Less than 75% R.H. non-condensing, +31°C to +40°C. Less than 45% R.H. non-condensing, +41°C to +50°C.
Radiated Emissions:	Complies with VXIbus Specification.
Conducted Emissions:	Complies with VXIbus Specification.
Module Envelope Dimensions:	VXI C size. 262 mm x 353 mm x 30.5 mm (10.3 in x 13.9 in x 1.2 in)
Dimensions, Shipping:	When ordered with a Tek/CDS mainframe, this module will be installed and secured in one of the instrument module slots (slots 1-12). When ordered alone, the card's shipping dimensions are: 406 mm x 305 mm x 102 mm. (16 in x 12 in x 4 in).
Weight:	1.60 kg (3.56 lbs.)
Weight, Shipping:	When ordered with a Tek/CDS mainframe, this module will be installed and secured in one of the instrument module slots (slots 1-12). When ordered alone, the card's shipping weight is: 2.27 kg. (5.06 lbs.)
Mounting Position:	Any orientation.
Mounting Location:	Installs in an instrument module slot (slots 1-12) of a C or D size VXIbus mainframe. (Refer to D size mainframe manual for information on required adapters.)
Front Panel Signal Connectors:	2 DD-50P connectors. Refer to Appendix B for connector pinouts.
Recommended Cables:	Two VX1727 Data cables.
Equipment Supplied:	1 - VX4353 Module. 1 - Operating Manual (Part # 00000-34353). 1 - Service Manual (Part # 00000-44353).
Optional Equipment:	2 - VX1727 Cables or VX1780S Connectors.

Section 1

Section 2

Preparation For Use

Installation Requirements And Cautions

The VX4353 Module is a C size VXIbus instrument module and therefore may be installed in any C or D size VXIbus mainframe slot other than slot 0. If the module is being installed in a D size mainframe, consult the operating manual for the mainframe to determine how to install the module in that particular mainframe. Setting the module's Logical Address switch defines the module's programming address. Refer to the Controls and Indicators subsection for information on selecting and setting the VX4353 Module's logical address.

Tools Required

The following tools are required for proper installation:

Slotted screwdriver set.

CAUTION

Note that there are two printed ejector handles on the card. To avoid installing the card incorrectly, make sure the ejector marked "VX4353" is at the top.

In order to maintain proper mainframe cooling, unused mainframe slots must be covered with the blank front panels supplied with the mainframe.

Based on the number of instrument modules ordered with the mainframe, blank front panels are supplied to cover all unused slots. Additional VXIbus C size single-slot and C size double-slot blank front panels can be ordered from your Tektronix supplier.

CAUTION

Verify that the mainframe is able to provide adequate cooling and power with this module installed. Refer to the mainframe Operating Manual for instructions.

If the VX4353 is used in a VX1X Series Mainframe, all VX4353 cooling requirements will be met.

CAUTION

If the VX4353 Module is inserted in a slot with any empty slots to the left of the module, the VME daisy-chain jumpers must be installed on the backplane in order for the VX4353 Module to operate properly. Check the manual of the mainframe being used for jumpering instructions.

If a Tek/CDS VX1400 or VX1401 mainframe is being used, the jumper points may be reached through the front of the mainframe. There are five (5) jumpers that must be installed for each empty slot. The five jumpers are the pins to the left of the empty slot.

Installation Procedure

CAUTION

The VX4353 Module is a piece of electronic equipment and therefore has some susceptibility to electrostatic damage (ESD). ESD precautions must be taken whenever the module is handled.

- 1) Record the module's revision level, serial number (located on the label on the top shield of the VX4353), and switch settings on the Installation Checklist. Only qualified personnel should perform this installation.
- 2) Verify that the switches are switched to the correct values. The Halt switch should be in the ON position unless it is desired to not allow the resource manager to reset this module.

Note that with either Halt switch position, a "hard" reset will occur at power-on and when SYSRST* is set true on the VXIbus backplane. If the module's commander is a Tek/CDS Resource Manager/IEEE-488 Interface Module, SYSRST* will be set true whenever the Reset switch on the front panel of that module is depressed. Also note that when the Halt switch is in the OFF position, the operation of this module is not VXIbus compatible.

- 3) The module can now be inserted into any slot of the chassis other than slot 0.

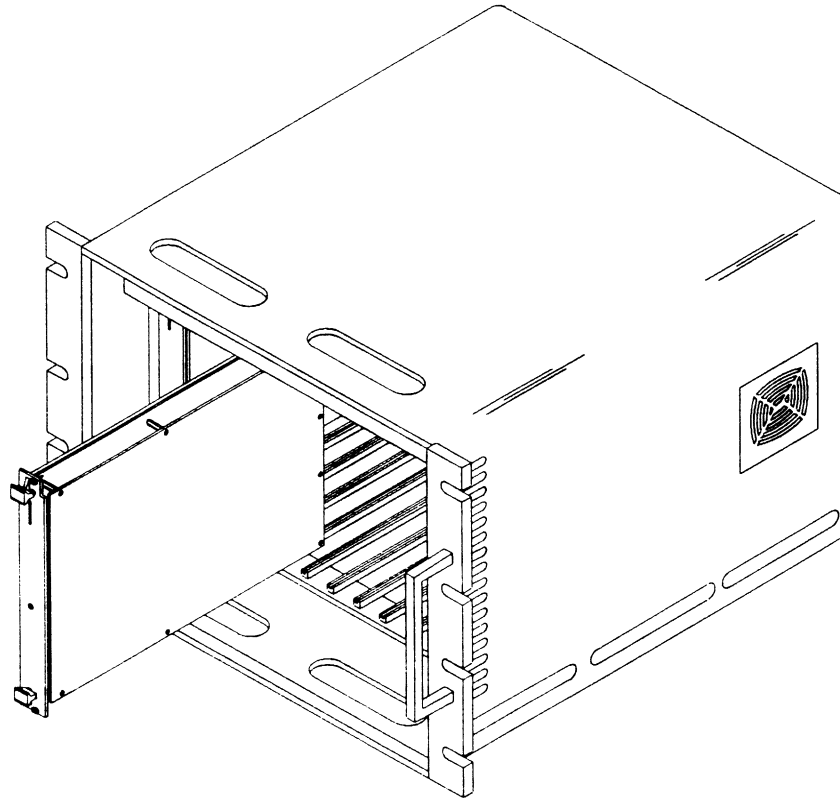

Figure 4: Module Installation

- 4) Install the cables - Use two VX1657S Analog Cables to interface between the module's output connector and the Unit Under Test (UUT). If the module is being installed in a Tektronix/CDS VX1400 or VX1401 Mainframe, route the cables from the front panel of the module down through the cable tray at the bottom of the mainframe and out the rear of the mainframe.

If a special cable is needed, a VX1780S Hooded Connector may be used to cable between the module output connector and the UUT.

Installation Checklist

Installation parameters may vary depending on the mainframe being used. Be sure to consult the mainframe Operating Manual before installing and operating the VX4353 Module.

Revision Level: _____

Serial No.: _____

Mainframe Slot Number: _____

Switch Settings:

VXibus Logical Address Switch: _____

Halt Switch: _____

Cable / Hooded Connector Installed:

VX1657S Cables: ____

VX1780S Connectors: ____

Performed by: _____ Date: _____

Installation Checklist

Installation parameters may vary depending on the mainframe being used. Be sure to consult the mainframe Operating Manual before installing and operating the VX4353 Module.

Revision Level: _____

Serial No.: _____

Mainframe Slot Number: _____

Switch Settings:

VXibus Logical Address Switch: _____

Halt Switch: _____

Cable / Hooded Connector Installed:

VX1657S Cables: ____

VX1780S Connectors: ____

Performed by: _____ Date: _____

Section 2

Section 3

Operation

Overview

The VX4353 Relay Switching Module provides 32 independently controlled single-pole, single-throw relays. Individual relays or all relays can be opened or closed under program control.

The amount of delay between successive operations and relay closure dwell time can be controlled by software. Delay times from 0 to 65535 milliseconds can be selected.

The VX4353 Module is programmed by ASCII characters issued from the system controller to the VX4353 Module via the module's VXIbus commander and the VXIbus mainframe backplane. The module is a VXIbus Message Based instrument and communicates using the VXIbus Word Serial Protocol. Refer to the manual for the VXIbus device that will be the VX4353 Module's commander for details on the operation of that device.

If the module commander is a Tek/CDS Resource Manager/IEEE-488 Interface Module, refer to that Operating Manual and the programming examples in the Operation section of this manual for information on how the system controller communicates with the commander being used.

Power-up

The VX4353 Module will complete its self test and be ready for programming five seconds after power-up. The VXIbus Resource Manager may add an additional one or two second delay. The Power LED will be on, and all other LEDs off. The MSG LED will blink during the power-up sequence as the VXIbus Resource Manager addresses all modules in the mainframe. The default condition of the module after power-up is described in the SYSFAIL, Self Test and Initialization subsection. All relays will be open after power-up.

System Commands

Although these non-data commands are initiated by the VX4353's commander (for example, the Tek/CDS VX4521 Enhanced Slot 0/Resource Manager) rather than the system controller, they have an effect on the VX4353 Module.

Module Commands

A summary of the VX4353's Module's commands is listed below. The summary also shows any required order of programming needed for commands. This is followed by detailed descriptions of each of the commands. A sample BASIC program using these commands is shown at the end of this section.

Command Syntax

Command protocol and syntax for the VX4353 Module are as follows:

- o Commands may be used in either the long or short form.
- o Any character may be sent in either upper or lower case form.
- o Commands are executed on receipt.
- o The message terminator may be a line feed and/or EOI bit.
- o Query commands (Q, T, and IDN?) require a terminator. All other commands may be strung together with only the final command in the string requiring a terminator.

Summary

An overview of the commands, in the order they typically would be programmed, is as follows:

<u>Short/Long Form</u>	<u>Effect</u>
Dz DELAYz	assigns time delay.
R RESET	resets (opens) all relays.
S SET	sets (closes) all relays.
Cz CLOSEz	closes relay z.
Oz OPENz	opens relay z.
Qz QUERYz	queries relay z for status.
T TIME?	queries time delay.
IDN?	returns identification message.

A detailed description of each command, in alphabetical order, is given in the following pages.

Command Descriptions

Command: CLOSE (Close a single relay)

Syntax: Cz or CLOSEz

Purpose: This command Closes a single relay on the VX4353 Module.

Description: z a 1- or 2-digit decimal number (0-31) which specifies the relay to be closed by the C command.

If the addressed relay is already closed, it will remain closed. The module will not accept the next command in the command sequence until the Delay time has elapsed.

Valid relay numbers are 1- or 2-digit ASCII numbers from 00 to 31. A relay number above 31 will not cause any action or delay time.

Examples: The command "C04" closes relay 4. Closing relay 4 will turn on Channel LED 4.

The command:

"R00C1C00C24"

would open any closed relays and close relays 00, 01, and 24. Channel LEDs 00, 01, and 24 will be lit. The delay time set by the Delay command occurs after the reset and after the closing of each relay.

Note that the command sequence does not require a terminator.

Command: DELAY (set delay time)

Syntax: Dz or DELAYz

Purpose: This command assigns the time delay.

Description: z the time delay value, from 0 to 65,535 milliseconds.

The Delay command controls the amount of delay between successive relay operations. Once the delay is programmed, any commands will be delayed by the specified interval. This delay interval will remain valid until another value is programmed or until a Sysreset is issued.

Note that since this delay holds off the controller, the timeout of the controller and the next subsequent command must be greater than the total time of the relay commands sent.

Example: The command

"D500C0C1C2"

programs the delay interval to be 500 ms, and closes relays 0, 1, and 2. There will be a 500 ms delay between each relay closing.

Command: IDN? (Identification)

Syntax: IDN?

Purpose: This command provides identification information about the module.

Description: When this command is issued, the module will return specific information about the module. This includes manufacturer's model number, type of device, and version of software.

Note that this command will not return a response until the terminator <CR> <LF> is received.

Response

Syntax: The module returns a string consisting of four parameters, separated by semi-colons:

param1; param2; param3; param4

param1	manufacturer and model code
param2	type of module
param3	version of software
param4	date of software release

Example: The command

"IDN?"

could return the following string for this board:

Tek/CDS VX4353; 32 Channel Switching Module; Ver 1.0; JAN 30, 1992

Command: OPEN (Open a single relay)

Syntax: Oz or OPENz

Purpose: This command Opens a single relay on the VX4353 Module.

Description: z a 1- or 2-digit decimal number (00-31) which specifies the relay to be opened by the O command.

Valid relay numbers are 1- or 2-digit ASCII numbers from 00 to 31. A relay number above 31 will not cause any action or delay time.

The module will not accept the next command in the command sequence until the Delay time has elapsed.

Examples: If relays 4 and 5 are closed, the command:

"004"

opens relay 4 on the VX4353 Module. Only relay 5 will remain closed and only Channel LED 5 will remain lit.

The command:

"R00C0C1C2C3C4O3"

opens any closed relays, closes relays 0, 1, 2, 3, and 4, then re-opens relay 3. The time between execution of each of the commands in the sequence depends on the rate the string is transmitted and the Delay time setting.

Command: QUERY? (Query a relay)
Syntax: Qz or QUERY?z
Purpose: The Query command selects a particular relay for status query, without changing its current state.
Description: z a 1- or 2-digit decimal number (00-31) which specifies the relay to be queried by the Q command.

A read from the VX4353 Module will return the status of the last relay selected. A relay is selected when it is set or reset (S or R commands), or by use of the Query command. The Query command allows selecting a relay without changing its current state.

Following this command, a read from the VX4353 will return either a 0 for open, or a 1 for closed. The module will not accept the next command in the command sequence until the Delay time has elapsed.

A "Cz" or "Oz" command also selects relay z for query. However, only the last relay specified in a command sequence will be selected. A read following the command "C00C01C03" would return the status of relay 3.

Valid relay numbers are 1- or 2-digit ASCII numbers from 00 to 31. A relay number above 31 will not cause any action or delay time.

Note that this command will not return a response until the terminator <CR> <LF> is received.

Response

Syntax: The module returns a 3-character ASCII string consisting of a "1" or "0", a carriage return (hex D) and a line feed (hex A). The END bit (which translates to a GPIB EOI bit in an IEEE-488 system) is set on the line feed character.

<u>Response</u>	<u>Indicates</u>
<u>0<CR><LF></u>	open
<u>1<CR><LF></u>	closed

Examples: The command:

"Q03"

selects relay 3. If relay 3 is open and the VX4353 is read, 0<CR><LF> will be returned.

Command: RESET (Reset all relays)

Syntax: R[z] or RESET[z]

Purpose: This command Resets (opens) all relays on the VX4353 Module.

Description: An "R" in the command sequence opens all relays on the VX4353 Module. After this command, all the Relay LEDs will be off.

The optional [z] after the "R" initiates a delay. If z is specified, the module will not accept the next command in the command sequence until the Delay time has elapsed. z may be any valid relay number from 00 to 31 (usually 00). If any relay number is used, all relays will be opened and the delay specified by the Delay command will be initiated.

Example: The command:

"R00C00C24R00"

opens all relays, closes relay 0, closes relay 24, and then opens all relays again.

Command: SET (Set all relays)

Syntax: S[z] or SET[z]

Purpose: This command Sets (closes) all relays on the VX4353 Module.

Description: An "S" in the command sequence closes all relays on the VX4353 Module. After this command, all the Relay LEDs will be on.

The optional [z] after the "S" initiates a delay. If z is specified, the module will not accept the next command in the command sequence until the Delay time has elapsed. z may be any valid relay number from 00 to 31 (usually 00). If any relay number is used, all relays will be closed and the delay specified by the Delay command will be initiated.

Example: The command:

"S00O00O24R00"

closes all relays, opens relay 0, opens relay 24, and then opens all relays.

Command: TIME? (query time delay)

Syntax: T or TIME?

Purpose: This command returns the delay value.

Description: The delay value set by the Delay command is returned.

Response

Syntax: The module returns a string consisting of up to five numbers, a carriage return (hex D), and a line feed (hex A). The End bit, which translates to a GPIB EOI bit in the IEEE-488 system, is set on the line feed character.

The response format is `n<CR><LF>`

where 'n' is a numeric value from 0 to 65,535, representing the delay value in milliseconds.

Note that this command will not return a response until the terminator `<CR><LF>` is received.

Example: The commands

```
"D100"  
"T"
```

return

```
100<CR><LF>
```

The delay value is programmed for 100 milliseconds and this value is read back.

SYSFAIL, Self Test, and Initialization

The default condition of the VX4353 Module after the completion of power-up is that all relays are open.

SYSFAIL* becomes active if the module's +5V bus fuses open. In this case, the mainframe Resource Manager will not be able to set the Sysfail Inhibit bit in the module's Control register, since the module logic will have lost power.

Section 3

Section 4

Programming Examples

This section contains an example program which demonstrates how the various programmable features of the VX4353 are used. The example is written in BASIC using an IBM PC or equivalent computer as the system controller.

Definition of BASIC Commands

The programming example in this manual is written in Microsoft GW BASIC. The example uses the GW BASIC commands described below. If the programming language you are using does not conform exactly to these definitions, use the command in that language that will give the same result.

Command Result

CALL ENTER (R\$, LENGTH%, ADDRESS%, STATUS%)

The CALL ENTER statement inputs data into the string R\$ from the IEEE-488 instrument whose decimal primary address is contained in the variable ADDRESS%. Following the input, the variable LENGTH% contains the number of bytes read from the instrument. The variable STATUS% contains the number '0' if the transfer was successful or an '8' if an operating system timeout occurred in the PC. Prior to using the CALL ENTER statement, the string R\$ must be set to a string of spaces whose length is greater than or equal to the maximum number of bytes expected from the VX4353.

CALL SEND (ADDRESS%, OUT\$, STATUS%)

The CALL SEND statement outputs the contents of the string variable OUT\$ to the IEEE-488 instrument whose decimal primary address is contained in the variable ADDRESS%. Following the output of data, the variable STATUS% contains a '0' if the transfer was successful and an '8' if an operating timeout occurred in the PC.

END Terminates the program.

FOR/NEXT Repeats the instructions between the FOR and NEXT statements for a defined number of iterations.

GOSUB n Runs the subroutine beginning with line n. EX: GOSUB 750 - runs the subroutine beginning on line 750. The end of the subroutine is delineated with a RETURN statement. When the subroutine reaches the RETURN statement, execution will resume on the line following the GOSUB command.

GOTO n	Program branches to line n. EX: GOTO 320 - directs execution to continue at line 320.
IF/THEN	Sets up a conditional IF/THEN statement. Used with other commands, such as PRINT or GOTO, so that IF the stated condition is met, THEN the command following is effective. EX: IF I = 3, GOTO 450 - will continue operation at line 450 when the value of variable I is 3.
REM	All characters following the REM command are not executed. REM statements are used for documentation and user instructions. EX: REM **CLOSE ISOLATION RELAYS**
RETURN	Ends a subroutine and returns operation to the line after the last executed GOSUB command.
<CR>	Carriage return character, decimal 13.
<LF>	Line feed character, decimal 10.

Programming Examples In BASIC

The following sample BASIC program shows how commands for the VX4353 might be used. This example assumes that the VX4353 has logical address 24 and is installed in a VXibus mainframe that is controlled via an IEEE-488 interface from an external system controller, such as an IBM PC or equivalent using a Capital Equipment Corp. IEEE-488 interface. The VXibus IEEE-488 interface is assumed to have an IEEE-488 primary address of decimal 21 and to have converted the VX4353 Module's logical address to an IEEE-488 primary address of decimal 24.

Following the example, the data sent to and returned from the module is shown, with data returned by the module shown underlined.

The following program demonstrates communication with a VX4353.

Lines 10 through 40 initialize the PC's IEEE-488 interface card as a system controller with an IEEE-488 address of decimal 24.

Line 50 assigns the decimal IEEE-488 address of the VX4353 to the variable ADDR353%.

```
10 GOSUB 1000
20 ENTER = 21:SEND = 9 : INIT = 0
30 PC.ADDRESS% = 21 : CONTROL% = 0
40 CALL INIT (PC.ADDRESS%, CONTROL%)
50 ADDR353% = 24
60 O$ = "R00"
    Lines 60-80 send the Reset command to open all relays.
```

```

70 CALL SEND (ADDR353%,O$,STATUS%)
80 IF STATUS% <> 0 THEN PRINT "ERROR - IEEE-488 TIMEOUT":STOP
90 O$ = "C05"
    Lines 90-110 send the Close command to close relay 5.
100 CALL SEND (ADDR353%,O$,STATUS%)
110 IF STATUS% <> 0 THEN PRINT "ERROR - IEEE-488 TIMEOUT":STOP
120 O$ = "C03C08C27C25"
    Lines 120-140 send Close commands to close relays 3, 8, 27, and 25.
130 CALL SEND (ADDR353%,O$,STATUS%)
140 IF STATUS% <> 0 THEN PRINT "ERROR - IEEE-488 TIMEOUT":STOP
150 O$ = "Q08"
    Lines 150-170 send the Query command to select relay 8 for status.
160 CALL SEND (ADDR353%,O$,STATUS%)
170 IF STATUS% <> 0 THEN PRINT "ERROR - IEEE-488 TIMEOUT":STOP
180 R$ = SPACE$(3) : REM MAKE A PLACE TO RECEIVE.
    Lines 180-220 read the status of relay 8 and print the status to the screen.
190 CALL ENTER (R$,LENGTH%,ADDR353%,STATUS%)
200 IF STATUS% <> 0 THEN PRINT "ERROR - IEEE-488 TIMEOUT":STOP
210 IF LEFT$(R$,1) = "1" THEN PRINT "RELAY 8 CLOSED"
220 IF LEFT$(R$,1) = "0" THEN PRINT "RELAY 8 OPEN"
230 O$ = "O25O08"
    Lines 230-250 send the Open command to open relays 25 and 8.
240 CALL SEND (ADDR353%,O$,STATUS%)
250 IF STATUS% <> 0 THEN PRINT "ERROR - IEEE-488 TIMEOUT":STOP
260 R$ = SPACE$(3) : REM MAKE A PLACE TO RECEIVE.
    Lines 260-300 read the status of relay 8 and print the status to the screen.
270 CALL ENTER (R$,LENGTH%,ADDR353%,STATUS%)
280 IF STATUS% <> 0 THEN PRINT "ERROR - IEEE-488 TIMEOUT":STOP
290 IF LEFT$(R$,1) = "1" THEN PRINT "RELAY 8 CLOSED"
300 IF LEFT$(R$,1) = "0" THEN PRINT "RELAY 8 OPEN"
310 END

```

```

1000 ' Sub-routine identifies the memory location of CEC IEEE-488 Interface Card ROM.
1020 '
1030 FOR I = &H40 TO &HEC STEP &H4
1040 FAILED = 0: DEF SEG = (I * &H100)
1050 IF CHR$( PEEK (50) ) <> "C" THEN FAILED = 1
1060 IF CHR$( PEEK (51) ) <> "E" THEN FAILED = 1
1070 IF CHR$( PEEK (52) ) <> "C" THEN FAILED = 1
1080 IF FAILED = 0 THEN CECLOC = (I * &H100): I = &HEC
1090 NEXT I
1100 RETURN

```

Data sent and received:

```

R00<CR><LF>
C05<CR><LF>

```

Section 4

C03C08C27C25<CR> <LF>

Q08<CR> <LF>

1<CR> <LF>

O25O08<CR> <LF>

0<CR> <LF>

Appendix A

VXibus Operation

The VX4353 Module is a C size single slot VXibus Message-Based Word Serial instrument. It uses the A16, D16 VME interface available on the backplane P1 connector and does not require any A24 or A32 address space. The Module is a D16 interrupter.

The VX4353 Module is neither a VXibus commander nor a VMEbus master, and therefore it does not have a VXibus signal register. The VX4353 is a VXibus message based servant.

The module supports the Normal Transfer Mode of the VXibus, using the Write Ready and Read Ready bits of the module's Response register.

A Normal Transfer Mode Read of the VX4353 Module proceeds as follows:

1. The commander reads the VX4353's Response register and checks if the Write Ready bit is true. If it is, the commander proceeds to the next step. If not, the commander continues to poll the Write Ready bit until it becomes true.
2. The commander writes the Byte Request command (0DEFFh) to the VX4353's Data Low register.
3. The commander reads the VX4353's Response register and checks if the Read Ready bit is true. If it is, the commander proceeds to the next step. If not, the commander continues to poll the Read Ready bit until it becomes true.
4. The commander reads the VX4353's Data Low register.

A Normal Transfer Mode Write to the VX4353 Module proceeds as follows:

1. The commander reads the VX4353's Response register and checks if the Write Ready bit is true. If it is, the commander proceeds to the next step. If not, the commander continues to poll the Write Ready bit until it becomes true.
2. The commander writes the Byte Available command which contains the data (OBCXX or OBDXX depending on the state of the End bit) to the VX4353's Data Low register.

As with all VXibus devices, the VX4353 Module has registers located within a 64 byte block in the A16 address space. The VX4353 Module has no registers beyond those defined for VXibus message based devices. All communications with the module are through the data low register, the response register or the VXibus interrupt cycle. Any

attempt by another module to read or write to any undefined location of the VX4353's address space may cause incorrect operation of the module.

The base address of the VX4353 device's registers is determined by the device's unique logical address and can be calculated as follows:

$$\text{Base Address} = V * 40H + C000H$$

where V is the device's logical address as set in the logical address switches.

VX4353 Configuration Registers

Below is a list of the VX4353's Configuration registers with a complete description of each. In this list, RO = Read Only, WO = Write Only, R = Read, W = Write, and X = varies with the state of the interface. The offset is relative to the module's base address.

REGISTER DEFINITIONS

<u>Register</u>	<u>Address</u>	<u>Type</u>	<u>Value (Bits 15-0)</u>
ID Register	0000H	RO	1011 1111 1111 1100 (BFFCh)
Device Type	0002H	RO	1111 0110 1001 1110 (F69Eh)
Status	0004H	R	0X11 1111 1111 XX11
Control	0004H	W	0111 1111 1111 11XX
Offset	0006H	WO	Not used
Protocol	0008H	RO	1110 1111 1111 1111 (EFFFh)
Response	000AH	RO	Defined by state of the interface
Data High	000CH		Not used
Data Low	000EH	W	16-bit arbitrary data
Data Low	000EH	R	16-bit arbitrary data

The VXI Word Serial command 'Read Protocol' returns information describing the communication protocols the device supports. This knowledge is required for proper device communication. For the VX4353 device, the Read Protocol command returns:

FF6Bh

This value indicates the device supports the VXI V1.3 Specification, that the device supports VXIbus Instrument protocol, and that the device supports the WSP Trigger command.

Appendix B

Input/Output Connections

<u>Relay</u>	<u>Contact</u>	<u>VX4353 Connector</u>	<u>Relay</u>	<u>Contact</u>	<u>VX4353 Connector</u>
00	N.O. Wiper	P4-1 P4-2	14	N.O. Wiper	P4-30 P4-31
01	N.O. Wiper	P4-3 P4-4	15	N.O. Wiper	P4-32 P4-33
02	N.O. Wiper	P4-5 P4-6	16	N.O. Wiper	P5-1 P5-2
03	N.O. Wiper	P4-7 P4-8	17	N.O. Wiper	P5-3 P5-4
04	N.O. Wiper	P4-9 P4-10	18	N.O. Wiper	P5-5 P5-6
05	N.O. Wiper	P4-11 P4-12	19	N.O. Wiper	P5-7 P5-8
06	N.O. Wiper	P4-13 P4-14	20	N.O. Wiper	P5-9 P5-10
07	N.O. Wiper	P4-15 P4-16	21	N.O. Wiper	P5-11 P5-12
08	N.O. Wiper	P4-18 P4-19	22	N.O. Wiper	P5-13 P5-14
09	N.O. Wiper	P4-20 P4-21	23	N.O. Wiper	P5-15 P5-16
10	N.O. Wiper	P4-22 P4-23	24	N.O. Wiper	P5-18 P5-19
11	N.O. Wiper	P4-24 P4-25	25	N.O. Wiper	P5-20 P5-21
12	N.O. Wiper	P4-26 P4-27	26	N.O. Wiper	P5-22 P5-23
13	N.O. Wiper	P4-28 P4-29	27	N.O. Wiper	P5-24 P5-25

Appendix B

<u>Relay Contact</u>	<u>VX4353 Connector</u>
28 N.O. Wiper	P5-26 P5-27
29 N.O. Wiper	P5-28 P5-29
30 N.O. Wiper	P5-30 P5-31
31 N.O. Wiper	P5-32 P5-33
Ground	P4-17,50
Ground	P5-17,50

All other connections (P4 - 34 to 49 and P5 - 34 to 49) should not be connected to any signal. These are no-connects.

Appendix C

VXI Glossary

The terms in this glossary are defined as used in the VXIbus System. Although some of these terms may have different meanings in other systems, it is important to use these definitions in VXIbus applications. Terms which apply only to a particular instrument module are noted. Not all terms appear in every manual.

Term	Definition
Accessed Indicator	An amber LED indicator that lights when the module identity is selected by the Resource Manager module, and flashes during any I/O operation for the module.
ACFAIL *	A VMEbus backplane line that is asserted under these conditions: 1) by the mainframe Power Supply when a power failure has occurred (either ac line source or power supply malfunction), or 2) by the front panel ON/STANDBY switch when switched to STANDBY.
A-Size Card	A VXIbus instrument module that is 100.0 by 160 mm by 20.32 mm (3.9 by 6.3 in by 0.8 in), the same size as a VMEbus single-height short module.
Asynchronous Communication	Communications that occur outside the normal "command-response" cycle. Such communications have higher priority than synchronous communication.
Backplane	The printed circuit board that is mounted in a VXIbus mainframe to provide the interface between VXIbus modules and between those modules and the external system.
B-Size Card	A VXIbus instrument module that is 233.4 by 160 mm by 20.32 mm (9.2 by 6.3 in by 0.8 in), the same size as a VMEbus double-height short module.
Bus Arbitration	In the VMEbus interface, a system for resolving contention for service among VMEbus Master devices on the VMEbus.
Bus Timer	A functional module that measures the duration of each data transfer on the Data Transfer Bus (DTB) and terminates the DTB cycle if the duration is excessive. Without the termination capability of this module, a Bus Master attempt to transfer data to or from a non-

	<p>existent Slave location could result in an infinitely long wait for the Slave response.</p>
Client	<p>In shared memory protocol (SMP), that half of an SMP channel that does not control the shared memory buffers.</p>
CLK10	<p>A 10 MHz, ± 100 ppm, individually buffered (to each module slot), differential ECL system clock that is sourced from Slot 0 and distributed to Slots 1-12 on P2. It is distributed to each module slot as a single source, single destination signal with a matched delay of under 8 ns.</p>
CLK100	<p>A 100 MHz, ± 100 ppm, individually buffered (to each module slot), differential ECL system clock that is sourced from Slot 0 and distributed to Slots 1-12 on P3. It is distributed to each module slot in synchronous with CLK10 as a single source, single destination signal with a maximum system timing skew of 2 ns, and a maximum total delay of 8 ns.</p>
Commander	<p>In the VXIbus interface, a device that controls another device (a servant). A commander may be a servant of another commander.</p>
Command	<p>A directive to a device. There are three types of commands:</p> <p>In Word Serial Protocol, a 16-bit imperative to a servant from its commander.</p> <p>In Shared Memory Protocol, a 16-bit imperative from a client to a server, or vice versa.</p> <p>In a Message, an ASCII-coded, multi-byte directive to any receiving device.</p>
Communication Registers	<p>In word serial protocol, a set of device registers that are accessible to the commander of the device. Such registers are used for inter-device communications, and are required on all VXIbus message-based devices.</p>
Configuration Registers	<p>A set of registers that allow the system to identify a (module) device type, model, manufacturer, address space, and memory requirements. In order to support automatic system and memory configuration, the VXIbus standard specifies that all VXIbus devices have a set of such registers, all accessible from P1 on the VMEbus.</p>
C-Size Card	<p>A VXIbus instrument module that is 340.0 by 233.4 mm by 30.48 mm (13.4 by 9.2 in by 1.2 in).</p>

Custom Device	A special-purpose VXIbus device that has configuration registers so as to be identified by the system and to allow for definition of future device types to support further levels of compatibility.
Data Transfer Bus	One of four buses on the VMEbus backplane. The Data Transfer Bus allows Bus Masters to direct the transfer of binary data between Masters and Slaves.
DC SUPPLIES	
Indicator	A red LED indicator that illuminates when a DC power fault is detected on the backplane.
Device Specific Protocol	A protocol for communication with a device that is not defined in the VXIbus specification.
D-Size Card	A VXIbus instrument module that is 340.0 by 366.7 mm by 30.48 mm (13.4 x 14.4 in x 1.2 in).
DTB	See Data Transfer Bus.
DTB Arbiter	A functional module that accepts bus requests from Requester modules and grants control of the DTB to one Requester at a time.
DUT	Device Under Test.
ECLTRG	Six single-ended ECL trigger lines (two on P2 and four on P3) that function as inter-module timing resources, and that are bussed across the VXIbus subsystem backplane. Any module, including the Slot 0 module, may drive and receive information from these lines. These lines have an impedance of 50 ohms; the asserted state is logical High.
Embedded Address	An address in a communications protocol in which the destination of the message is included in the message.
ESTST	Extended SStart/STop protocol; used to synchronize VXIbus modules.
Extended Self Test	Any self test or diagnostic power-up routine that executes after the initial kernel self test program.
External System Controller	The host computer or other external controller that exerts overall control over VXIbus operations.
Failed Indicator	A red LED indicator that lights when a device on the VXIbus has detected an internal fault. This might result in the assertion of the SYSFAIL* line.

IACK Daisy Chain Driver	The circuit that drives the VMEbus Interrupt Acknowledge daisy chain line that runs continuously through all installed modules or through jumpers across the backplane.
ID-ROM	An NVRAM storage area that provides for non-volatile storage of diagnostic data.
Instrument Module	A plug-in printed circuit board, with associated components and shields, that may be installed in a VXIbus mainframe. An instrument module may contain more than one device. Also, one device may require more than one instrument module.
Interface Device	A VXIbus device that provides one or more interfaces to external equipment.
Interrupt Handler	A functional module that detects interrupt requests generated by Interrupters and responds to those requests by requesting status and identity information.
Interrupter	A device capable of asserting VMEbus interrupts and performing the interrupt acknowledge sequence.
IRQ	The Interrupt ReQuest signal, which is the VMEbus interrupt line that is asserted by an Interrupter to signify to the controller that a device on the bus requires service by the controller.
Local Bus	A daisy-chained bus that connects adjacent VXIbus slots.
Local Controller	The instrument module that performs system control and external interface functions for the instrument modules in a VXIbus mainframe or several mainframes. See Resource Manager.
Local Processor	The processor on an instrument module.
Logical Address	The smallest functional unit recognized by a VXIbus system. It is often used to identify a particular module.
Mainframe	Card Cage For example, the Tektronix VX1400 Mainframe, an operable housing that includes 13 C-size VXIbus instrument module slots.
Memory Device	A storage element (such as bubble memory, RAM, and ROM) that has configuration registers and memory attributes (such as type and access time).
Message	A series of data bytes that are treated as a single communication, with a well defined terminator and message body.

Message Based Device	A VXIbus device that supports VXI configuration and communication registers. Such devices support the word serial protocol, and possibly other message-based protocols.
MODID Lines	Module/system identity lines.
Physical Address	The address assigned to a backplane slot during an access.
Power Monitor	A device that monitors backplane power and reports fault conditions.
P1	The top-most backplane connector for a given module slot in a vertical mainframe such as the Tektronix VX1400. The left-most backplane connector for a given slot in a horizontal mainframe.
P2	The bottom backplane connector for a given module slot in a vertical C-size mainframe such as the VX1400; or the middle backplane connector for a given module slot in a vertical D-size mainframe such as the VX1500.
P3	The bottom backplane connector for a given module slot in a vertical D-size mainframe such as the Tektronix VX1500.
Query	A form of command that allows for inquiry to obtain status or data.
READY Indicator	A green LED indicator that lights when the power-up diagnostic routines have been completed successfully. An internal failure or failure of +5-volt power will extinguish this indicator.
Register Based Device	A VXIbus device that supports VXI register maps, but not high level VXIbus communication protocols; includes devices that are register-based servant elements.
Requester	A functional module that resides on the same module as a Master or Interrupt Handler and requests use of the DTB whenever its Master or Interrupt Handler requires it.
Resource Manager	A VXIbus device that provides configuration management services such as address map configuration, determining system hierarchy, allocating shared system resources, performing system self test diagnostics, and initializing system commanders.
Self Calibration	A routine that verifies the basic calibration of the instrument module circuits, and adjusts this calibration to compensate for short- and long-term variables.

Self Test	A set of routines that determine if the instrument module circuits will perform according to a given set of standards. A self test routine is performed upon power-up.
Servant	A VXIbus message-based device that is controlled by a commander.
Server	A shared memory device that controls the shared memory buffers used in a given Shared Memory Protocol channel.
Shared Memory Protocol	A communications protocol that uses a block of memory that is accessible to both client and server. The memory block operates as a message buffer for communications.
Slot 0 Controller	See Slot 0 Module. Also see Resource Manager.
Slot 0 Module	A VXIbus device that provides the minimum VXIbus slot 0 services to slots 1 through 12 (CLK10 and the module identity lines), but that may provide other services such as CLK100, SYNC100, STARBUS, and trigger control.
SMP	See Shared Memory Protocol.
STARX	Two (2) bi-directional, 50 ohm, differential ECL lines that provide for inter-module asynchronous communication. These pairs of timed and matched delay lines connect slot 0 and each of slots 1 through 12 in a mainframe. The delay between slots is less than 5 nanoseconds, and the lines are well matched for timing skew.
STARX	Two (2) bi-directional, 50 ohm, differential ECL lines that provide for inter-module asynchronous communication. These pairs of timed and matched delay lines connect slot 0 and each of slots 1 through 12 in a mainframe. The delay between slots is less than 5 nanoseconds, and the lines are well matched for timing skew.
STST	STart/STop protocol; used to synchronize modules.
SYNC100	A Slot 0 signal that is used to synchronize multiple devices with respect to a given rising edge of CLK100. These signals are individually buffered and matched to less than 2ns of skew.
Synchronous Communications	A communications system that follows the "command-response" cycle model. In this model, a device issues a command to another device; the second device executes the command; then returns a response. Synchronous commands are executed in the order received.
SYSFAIL*	A signal line on the VMEbus that is used to indicate a failure by a device. The device that fails asserts this line.

System Clock Driver	A functional module that provides a 16 MHz timing signal on the Utility Bus.
System Hierarchy	The tree structure of the commander/servant relationships of all devices in the system at a given time. In the VXIbus structure, each servant has a commander. A commander may also have a commander.
Test Monitor	An executive routine that is responsible for executing the self tests, storing any errors in the ID-ROM, and reporting such errors to the Resource Manager.
Test Program	A program, executed on the system controller, that controls the execution of tests within the test system.
Test System	A collection of hardware and software modules that operate in concert to test a target DUT.
TTLTRG	Open collector TTL lines used for inter-module timing and communication.
VXIbus Subsystem	One mainframe with modules installed. The installed modules include one module that performs slot 0 functions and a given complement of instrument modules. The subsystem may also include a Resource Manager.
Word Serial Protocol	A VXIbus word oriented, bi-directional, serial protocol for communications between message-based devices (that is, devices that include communication registers in addition to configuration registers).
Word Serial Communications	Inter-device communications using the Word Serial Protocol.
WSP	See Word Serial Protocol.
10 MHz Clock	A 10 MHz, ± 100 ppm timing reference. Also see CLK10.
100 MHz Clock	A 100 MHz, ± 100 ppm clock synchronized with CLK10. Also see CLK100.
488-To-VXIbus Interface	A message based device that provides for communication between the IEEE-488 bus and VXIbus instrument modules.